

### 3/2 N.O. or N.C. Air-Piloted Valves

Medium:  
Air

Material:  
Anodized aluminum body, Nitrile diaphragms

Input Pressure:  
0.7 to 7 bar

Air Flow:  
625 L/min @ 7 bar

Minimum Pilot Pressure:  
N.O. - 90% of supply pressure  
N.C. - 60% of supply pressure

Response Time:  
15 milliseconds after pilot pressure reaches switch point

Operating Speed:  
1.100 CMP

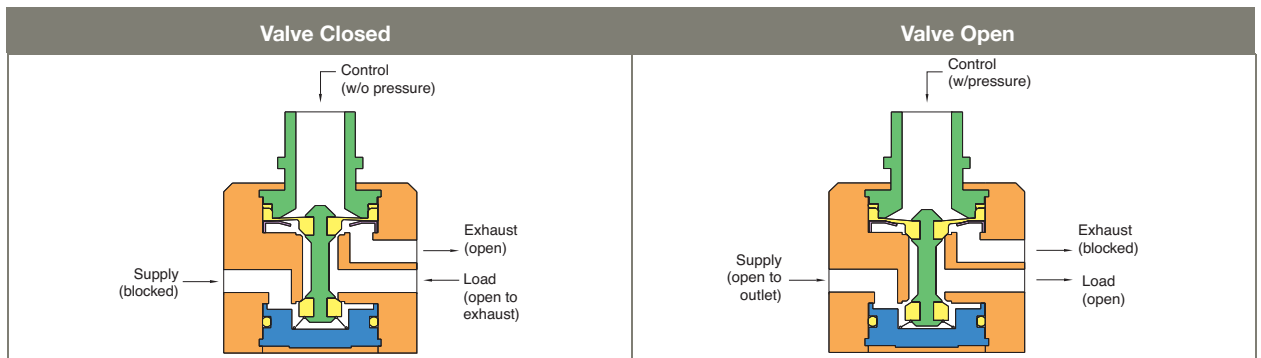
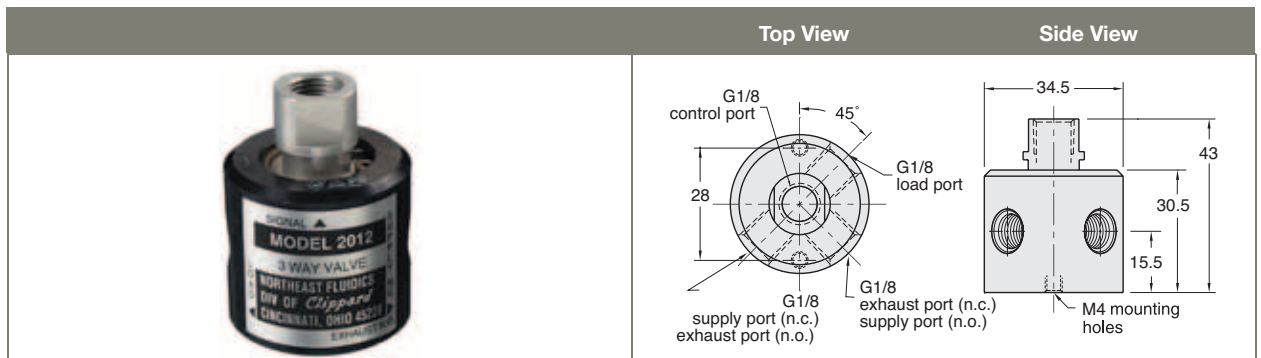

Part No.	Description
M-2012	Pilot Valve, G1/8
M-2012-VAC	Valve for Vacuum Operation (requires positive pressure pilot signal)
M-2012-G	Valve for Liquid Adhesives (silicon diaphragm and seals), G1/8

### Flat Bracket

Flat mounting bracket available. See page 61.

Part No.	Description
M-2010-050	Flat Bracket

